

INDUSTRIAL SOLUTIONS



Contact:

+ 1.800.867.4580

Website :

www.ljcommercialproducts.com

Address :

2001 Challenger Avenue
Suite A
Oroville, CA 95965, USA

Welcome To **LJ** Commercial

Air-Powered Laundry Transport Systems



Revolutionize Your Business with
Cutting-Edge Air-power Technology

Table Of Contents

Benefits of Air-power Transport for Your Business

- Reliable Automated System
- Labor Savings with Automated Features
- Versatile Vertical and Horizontal Transport
- Unprecedented Speed of Delivery
- Suitable for a Wide Variety of Items
- Modular and Scalable System
- Rapid Return on Investment
- Easy Maintenance and Cleaning
- Integration with Air Filtration and Conditioning
- Hands free options improve workplace hygiene

01

Examples of Commercial Applications

- Factory Apparel Transport
- Locker Room Laundry Transport
- Spas and Health Clubs
- Medical Centers and Hospitals
- Gyms
- Hotels
- Apparel Production and Sorting Facilities
- Cruise Ships

02

The System's Basic Components

- The Power Unit
- The Piping
- Port Entry Points
- Port Access Controls
- Control Systems

03

The Design Process with LJ Commercial

- Engineering Team Support
- 3D Design and Rendering
- Project Management
- Training and Support

04

Implementation

- Regular Update Meetings
- Installation Options
- Upgrades and Ongoing Service

05

Summary

06

How to Start Your Project

- Initial Consultation
- Commercial Application Info Gathering Form

07

Reliable Automated Systems

Our Commercial Air-Powered Laundry Transport Systems offer a reliable and automated solution for your laundry and apparel or fabric/soft material transport needs. Say goodbye to manual handling and wheeled carts and hello to maximum air powered efficiency.

Labor Savings with Automated Features

With automatic pick-up and sensing options such as color recognition, RFID tracking, and movement detection, you can significantly reduce labor costs and manual processes. The system takes care of the heavy lifting for you and speeds up transfer and delivery to the right place from hours and minutes to just seconds.

Versatile Vertical & Horizontal Transport

Our system can transport your items vertically along the roof or ceiling, saving valuable floor space. Alternatively, it can transport items downward to an underground or underfloor system, adapting to your layout requirements.

Unprecedented Speed of Delivery

Experience lightning-fast delivery with garments traveling at speeds exceeding 30 mph. Say goodbye to bottlenecks in your laundry and apparel distribution processes.

Suitable for a Wide Variety of Items

Our system's modular design allows it to handle a diverse range of items, from clothing and linens to towels and fabrics. We help you choose the pipe diameter and system power to suit your specific needs.



Modular & Scalable System

Need to expand or contract your laundry transport system? No problem. LJ Commercial's solution is modular and can adapt to your changing requirements, whether you're transporting laundry across 10 feet or over 2000 feet.

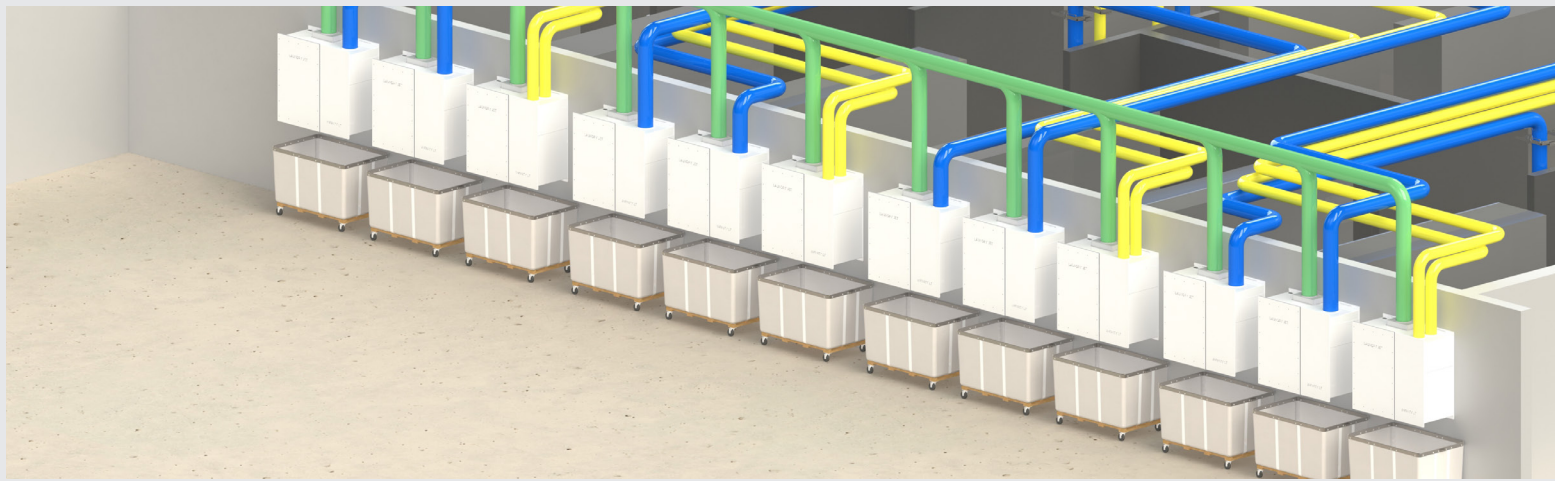

Rapid Return on Investment

Investing in LJ Commercial's Air-Powered Laundry Transport System translates to a swift return on investment. The labor savings and efficiency gains will make a noticeable impact on your bottom line from day 1.

Easy Maintenance and Cleaning

Keeping your system running smoothly is a breeze with our easy-to-maintain design. Cleaning options are available if required, ensuring your system remains in top condition.

Integration with Air Filtration and Conditioning

Our system's design can also incorporate internal air flow, conditioning, and pressure requirements. Plus, it can interact seamlessly with air filtration systems if necessary and feasible for your facility.



Examples of Commercial Applications

Our Commercial Air-Powered Laundry Transport System is highly versatile and finds applications across various industries.

Factory Apparel Transport

Efficiently move clothing and textiles within large manufacturing facilities, reducing labor costs and improving production flow.



Locker Room Laundry Transport

In sports complexes, workplaces, and educational institutions, our system ensures that clean and fresh uniforms and garments are readily available for use.



Spas, Gyms and Health Clubs

Maintain a consistent supply of clean towels and linens in spas, gyms and health clubs, enhancing customer satisfaction.



Medical Centers and Hospitals

Streamline the distribution of clean scrubs, gowns, and linens throughout medical facilities, ensuring hygiene and efficiency.



Hotels

Efficiently manage the transport of bedding, towels, and linens, ensuring that rooms are always well-prepared for guests.



Apparel Production and Sorting Facilities

Facilitate the movement of garments through various stages of production and sorting, improving overall efficiency.



Cruise Ships

Optimize laundry logistics on cruise ships, ensuring a constant supply of clean linens and uniforms for passengers and crew.



The Systems Basic Components

Our patented Commercial Air-Powered Laundry Transport System is built on cutting-edge airflow technology and components, ensuring a customized solution for your specific needs.

The Power Unit

Choose from a range of power units, including 1000 CFM to 6,000 CFM. Custom units can be designed if required. The power unit is the heart of the system, determining its transport capabilities.

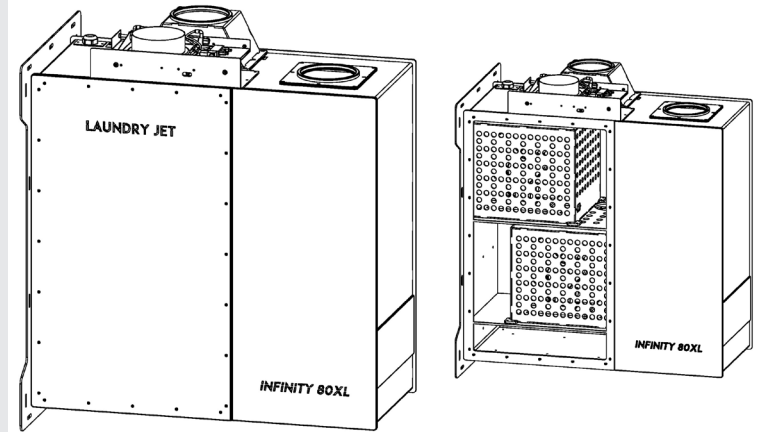

The Piping

Select from 6", 8", or 10" piping, depending on your required volume, distance, and power unit choice. Pipe size is determined by the size of the transport item, volume and the distance to drop point.

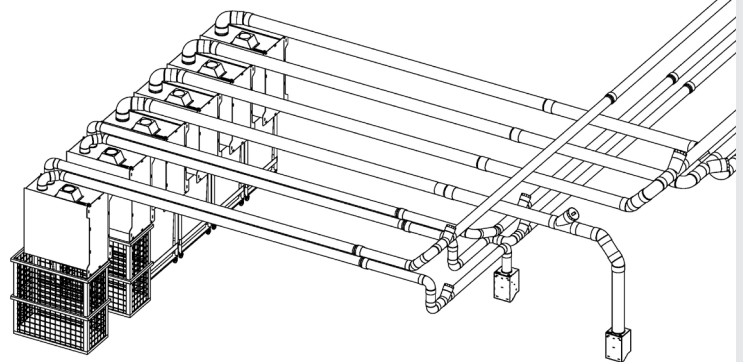

Port Entry Points

Customize your system with automatic or manual load entry points. You can also incorporate sensor options such as color recognition, RFID tracking, and movement detection for precise control.

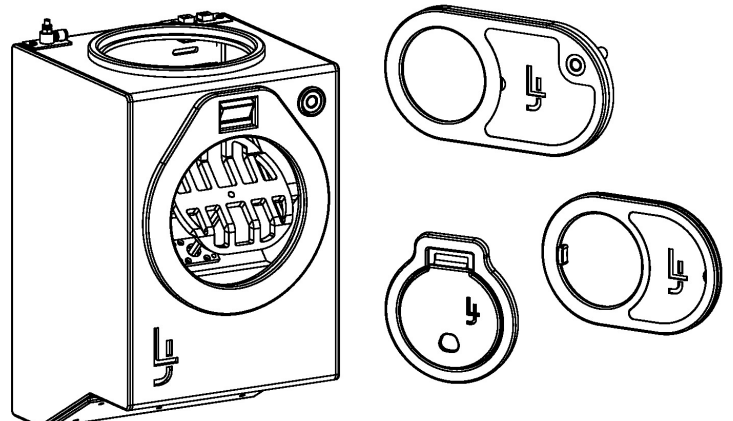

Port Access Controls

Ensure safety and control with lockouts and other safety features at port access points, guaranteeing smooth operation and minimizing risks.



Control Systems

Tailor your control system to your preferences. Options range from remote control to centralized PLC systems and fully digital interfaces, providing you with flexibility and ease of use



The Design Process with LJ Commercial

At LJ Commercial, we prioritize the success of your project(s). Our comprehensive design process ensures your needs are met every step of the way

Fully Engaged Engineering Team Support

Ensure safety and control with lockouts and other safety features at port access points, guaranteeing smooth operation and minimizing risks.



3D Design with Rendering, Video, and Conceptualization

Visualize your project in detail with 3D designs, rendering, and video presentations. We bring your vision to life before implementation.

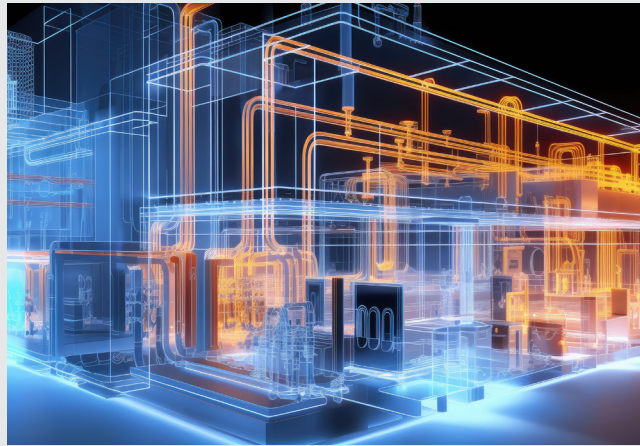

Project Management

From agreed project deliverables to cost estimates and implementation schedules, we provide comprehensive project management support.

Training, System Support, and Service

We don't just stop at installation. We offer training for your team, ongoing system support, and maintenance services to ensure your system runs smoothly throughout its life cycle.



Implementation

Once the project parameters, deliverables, and schedules have been agreed upon, we follow a structured implementation process.

Regular Update Meetings

Stay informed with regular update meetings, ensuring that the project progresses smoothly according to plan.

Installation Options

Choose from full, partial, or self-installation, with the option to use internal or third-party installers. We tailor our services to your preferences.

Upgrades and Ongoing Service

As your business evolves, LJ Commercial is here to support you with system upgrades and ongoing maintenance services, ensuring your system remains efficient and up-to-date.



In summary, **LJ Commercial's Air-Powered Laundry Transport System** is a game-changer for businesses seeking to enhance efficiency, reduce labor costs, and streamline laundry and apparel distribution.

With a wide range of applications, cutting-edge components, and a thorough design and implementation process, our system is ready to transform your operations.

Contact us today to take the first step toward a more efficient future.



How to Start Your Project

Embark on your journey towards a more efficient laundry and apparel transport system by reaching out to us. Here's how to get started:

Initial Consultation

Contact us at graeme@ljcommercialproducts.com to arrange a free initial consultation. We'll provide feedback on approximate timelines, ballpark costs, and return on investment calculations specific to your project.

Commercial Application Info Gathering Form

Submit your information through our commercial application info gathering form to initiate the engagement process. We'll work closely with you to understand your unique requirements. Click here to submit your requirements <https://laundryjet.com/form-view/7>



LJ COMMERCIAL

LJ Commercial, LLC | 2001 Challenger Avenue, Suite A | Oroville, CA, USA 95965

+1.800.867.4580 | www.ljcommercialproducts.com | graeme@ljcommercialproducts.com